

# Jack Chair

turnstone®

## 1. Inserting The Casters or Glides

Insert the shafts of the casters (or glides) into their corresponding sockets on the base. Make sure the casters (or glides) seat firmly. Stand the base upright.

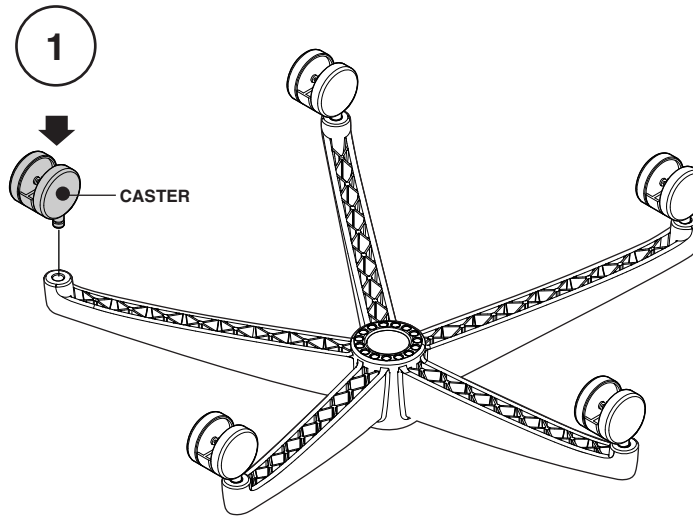

## 2. Inserting The Cylinder

With the base resting on the floor insert the cylinder as shown.

## Installation Of Optional Stool Kit

Insert the gas cylinder into the foot-ring and tighten the hand wheel. Insert the cylinder into the base as shown.

## 3. Attaching The Seat

Line up the top of the cylinder with the corresponding hole on the bottom of the mechanism and place the seat. Grabbing both sides of the seat pan firmly push the entire chair towards the floor to properly seat the tapers of the cylinder into the seat and base.

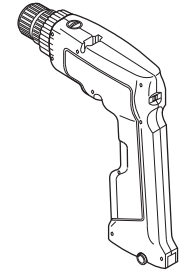
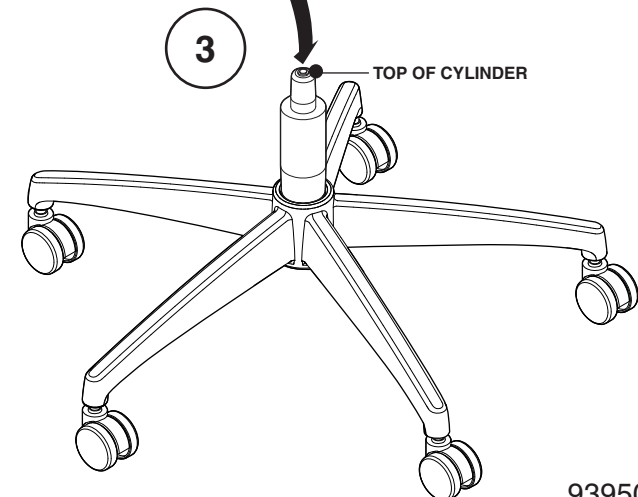
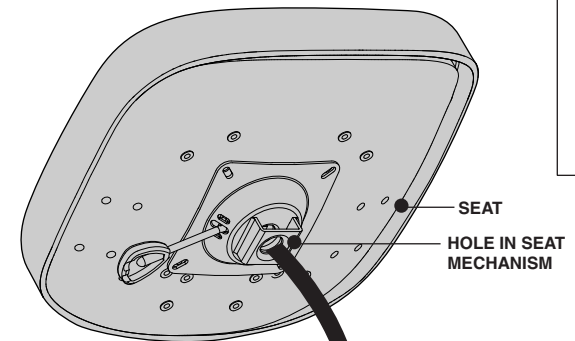
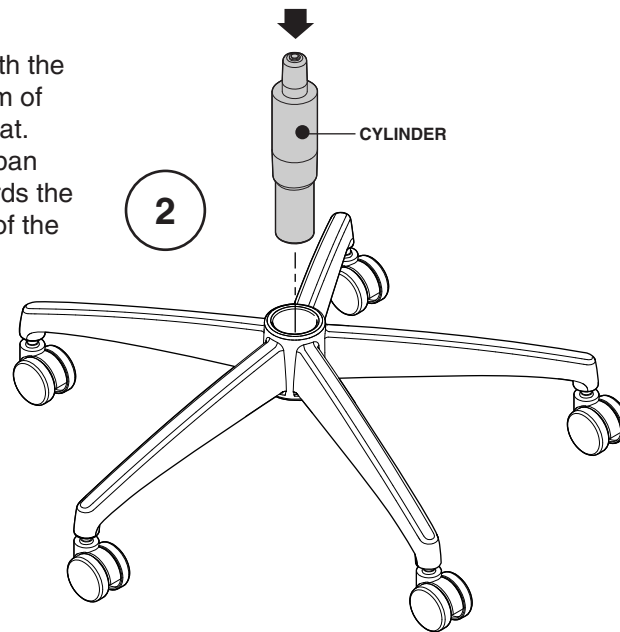

5/32  
BALL HEAD HEX DRIVE

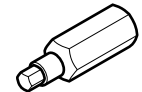

5MM  
HEX DRIVE

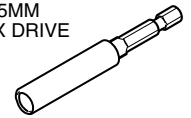

#### 4. Attaching The Back Fixed Height

Attach the J-Bar to the seat pan using the four (4) M8 screws.

#### Adjustable Height

Insert the J-Bar into the corresponding slot on the mechanism. Secure the J-Bar to the mechanism using the three (3) M8 screws.

#### 5. Optional Arm Installation

Attach the arms using the four (4) 1/4-20 screws.

**NOTE:** Insert rear screws first on all J-Bars.  
Start all screws before tightening any screws fully.

